

Electrical Specifications

Parameters		Value	Unit
Center Frequency		1575.42 ±3.0	MHz
Return Loss, typ	@ Fo	25	dB
Bandwidth, min	@ 10dB Return Loss	8	MHz
Gain, typ	@ Zenith	2.0	dB
Polarization		RHCP	-
Ground Plane		27 x 27	mm
Impedance		50	Ω
Frequency Temperature Coefficient		±20	ppm/ °C
Operating Temperature Range		-40 ~ +85	°C

Dimensions

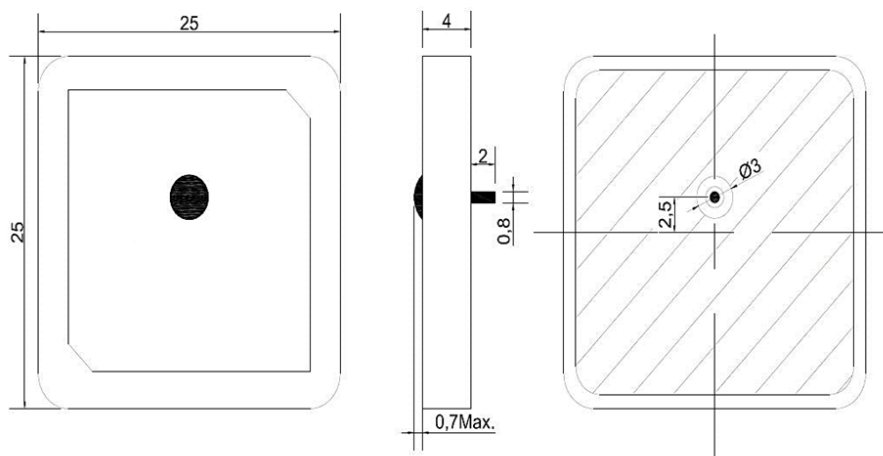

Tolerance Unless Otherwise Specified: ±0.30
Unit: mm

Text Fixture

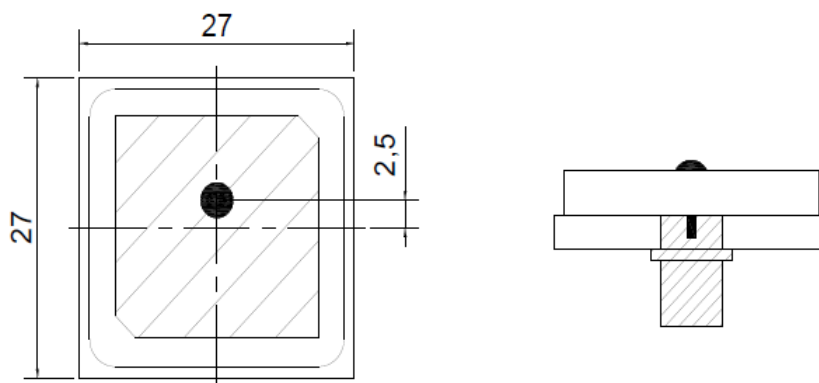

Frequency Characteristics

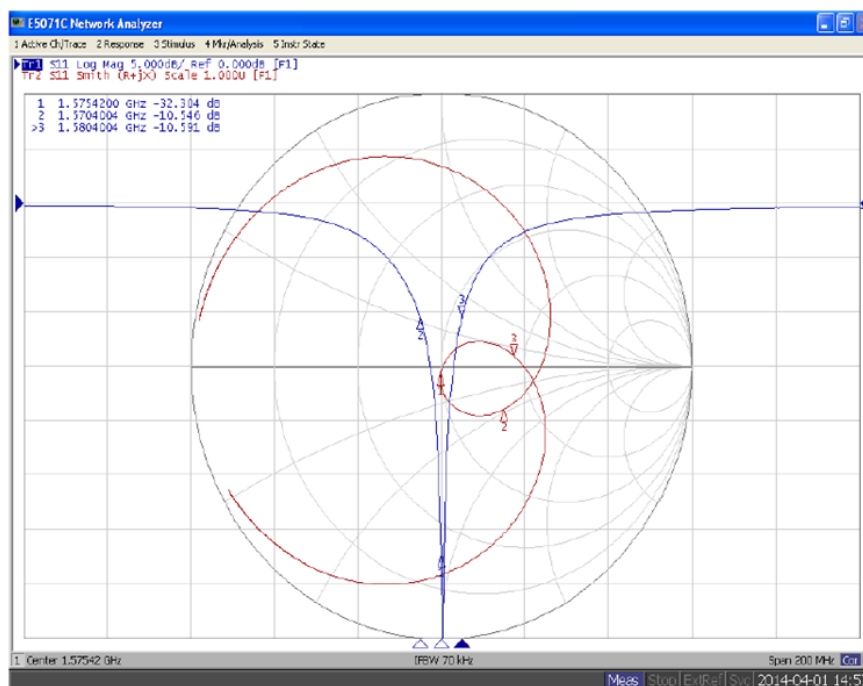

• APPROVAL

DRAWN BY	AR, September 04, 2019
APPROVED BY	CP, September 04, 2019
REVISION	A, Initial Release