

### ❖ ELECTRICAL SPECIFICATION

PARAMETER		VALUE
Frequency Range		13.500 ~ 156.250 MHz
Operating Temperature Range		-10°C ~ +70°C Standard -40°C ~ +85°C Extended
Frequency Stability		±25 ppm, ±50 ppm, ±100ppm
Storage Temperature Range		-55°C to +125°C
Supply Voltage (Vcc)		2.5 V, 3.3 V
Supply Current		40 mA max
Output LVDS	Symmetry at 50% V <sub>CC</sub>	40% to 60% 45% to 55%
	Rise / Fall Time	1 ns max at 20% ~ 80% Output swing level
	Logic "0" Level	0.9 V min
	Logic "1" Level	1.6 V max
	Load	100 Ω (OUT – OUTN Differential)
Enable / Disable Function		Pin 1: High or Open / Output enabled (Pins 4 & 5) Pin 1: Low / Output disabled (High impedance)
RMS Phase Jitter (12kHz ~ 20 MHz)		1 ps max
Peak to Peak Period Jitter		30 ps typ

❖ MECHANICAL SPECIFICATION

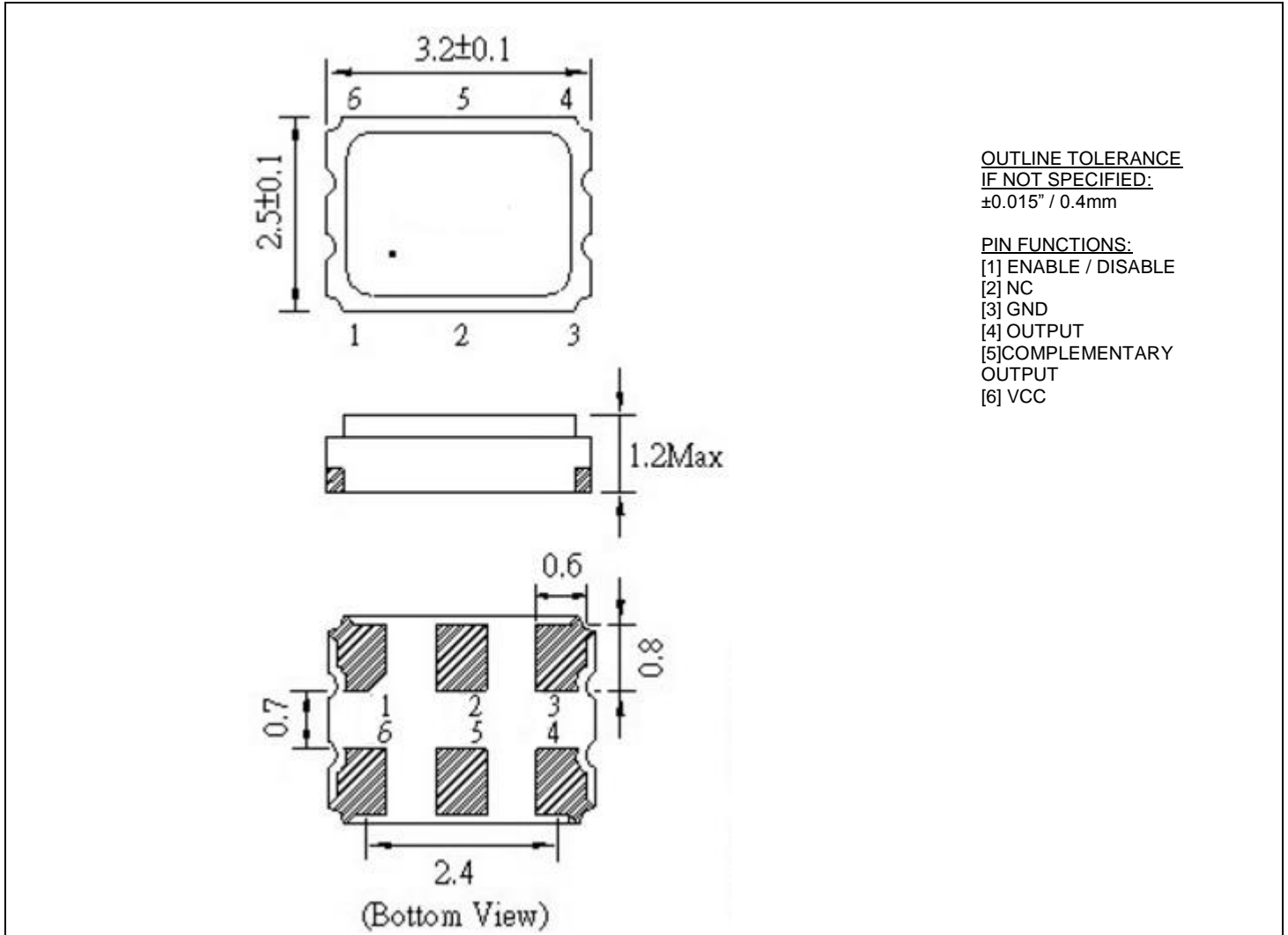

❖ PART NUMBERING SYSTEM

TYPE	SERIES	FREQUENCY (MHz)	SUPPLY VOLTAGE (Vcc)	STABILITY (ppm)	TEMPERATURE RANGE (°C)	SYMMETRY (Duty Cycle)	TAPE & REEL
Clock Oscillator RCL	3225	13.500 ~ 156.250 MHz	2.5: Vcc=2.5 3.3: Vcc=3.3	25: ±25 ppm 50: ±50 ppm 100: ±100 ppm	blank: -10°C to +70°C X: -40°C to +85°C	blank: 40 to 60% T: 45 to 55%	TR

**EXAMPLE: RCL3225-155.520-2.5-25-X-T-TR**

Surface Mount CL3225 LVDS Oscillator, 3.2 x 2.5 mm, 155.520 MHz, 2.5 VDC Supply Voltage, ±25 ppm Overall Stability, from -40°C to +85°C, Symmetry 45% to 55%, Tape and Reel packaging.

❖ REFLOW PROFILE

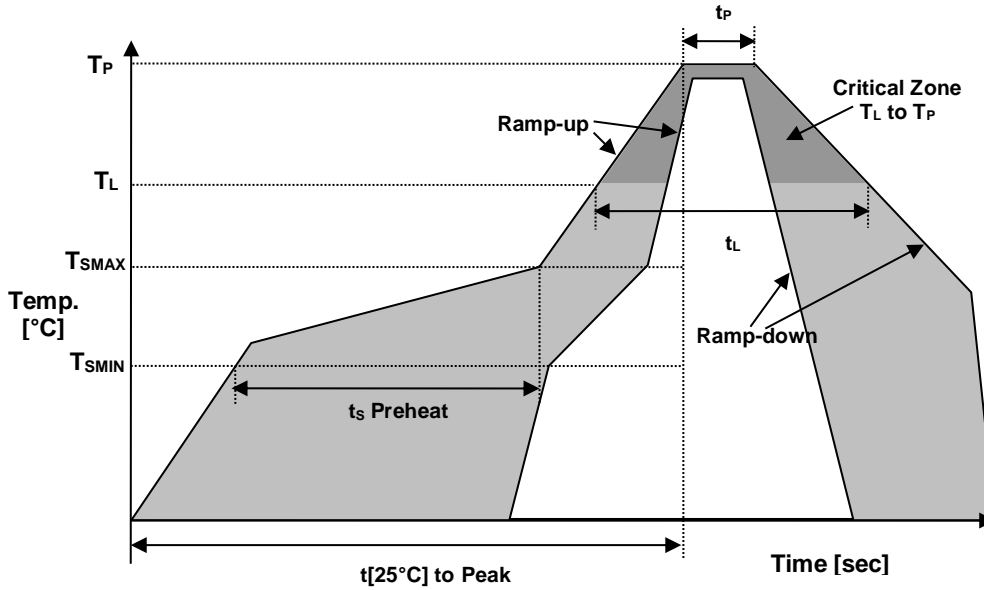

Reflow profile		
Temperature Min Preheat	T <sub>SMIN</sub>	150°C
Temperature Max Preheat	T <sub>SMAX</sub>	200°C
Time (T <sub>SMIN</sub> to T <sub>SMAX</sub> )	t <sub>s</sub>	60-180 sec.
Temperature	T <sub>L</sub>	217°C
Peak Temperature	T <sub>P</sub>	260°C
Ramp-up rate	R <sub>UP</sub>	3°C/sec max.
Ramp-down rate	R <sub>DOWN</sub>	6°C/sec max.
Time within 5°C of Peak Temperature	t <sub>p</sub>	10 sec.
Time t[25°C] to Peak Temperature	t[25°C] to Peak	480 sec.
Time	t <sub>L</sub>	60-150 sec.

❖ ENVIRONMENTAL

PARAMETER	VALUE
MOISTURE SENSITIVITY LEVEL	1
REACH SVHC	COMPLIANT
RoHS	COMPLIANT
TERMINATION FINISH	Au

