

❖ ELECTRICAL SPECIFICATION

PARAMETER		VALUE
Frequency Range		13.500 ~ 156.250 MHz
Operating Temperature Range		-10°C ~ +70°C Standard -40°C ~ +85°C Extended
Frequency Stability		±25 ppm, ±50 ppm, ±100ppm
Storage Temperature Range		-55°C to +125°C
Supply Voltage (Vcc)		2.5 V, 3.3 V
Supply Current		50 mA max
Output LVPECL	Symmetry	40% to 60% at 50% Vdd (45% to 55% Available)
	Logic "0" Level	Vcc - 1.620 V max
	Logic "1" Level	Vcc - 1.025 V min
	Load	50 Ω (to V _{CC} -2 V)
Enable / Disable Function		Pin 1: High or Open / Output enabled (Pins 4 & 5) Pin 1: Low / Output disabled (High impedance)
Rise / Fall Time		1 ns max at 20% ~ 80% Output swing level
RMS Phase Jitter (12kHz ~ 20 MHz)		1 ps max

❖ MECHANICAL SPECIFICATION

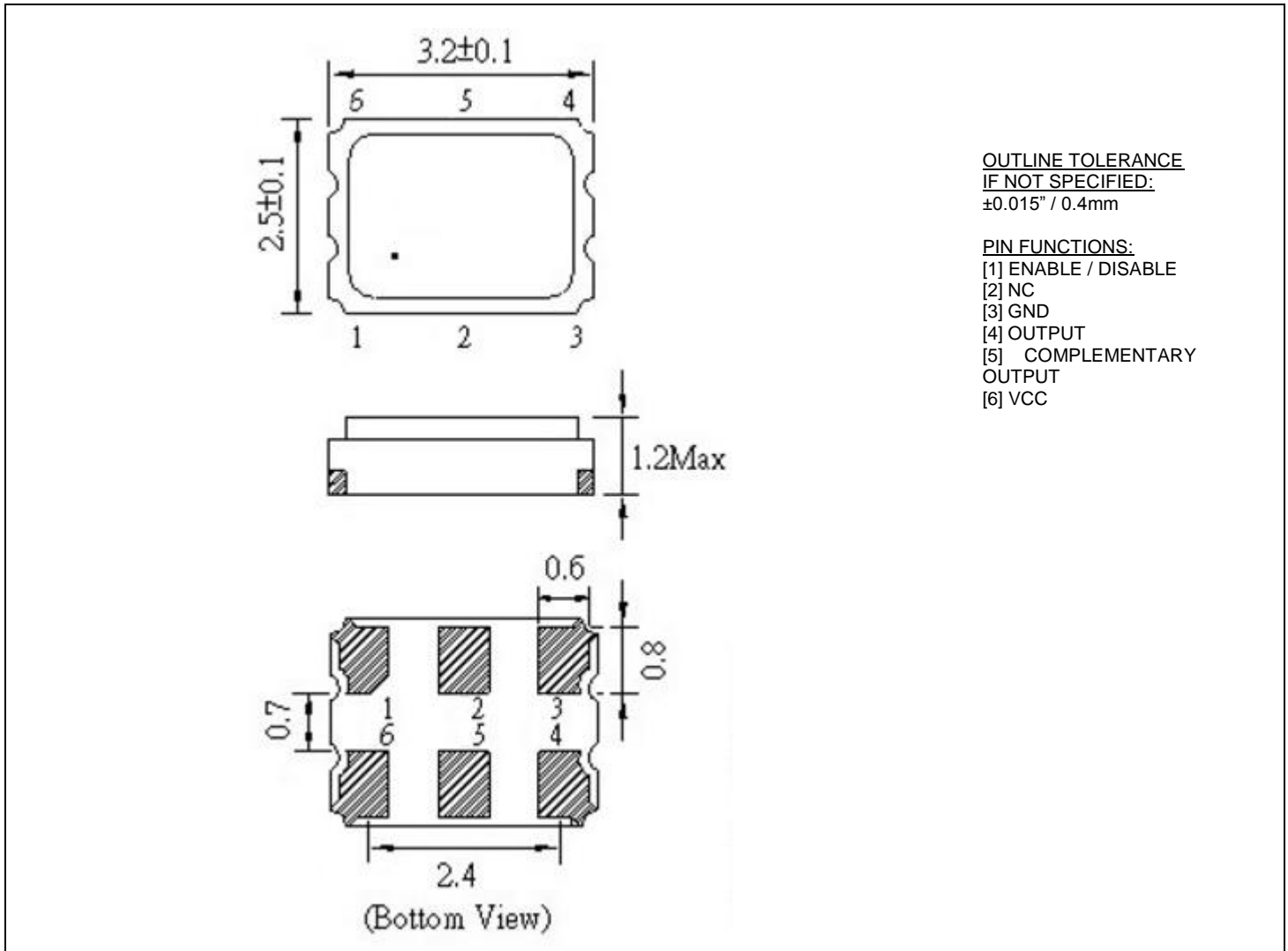

❖ PART NUMBERING SYSTEM

TYPE	SERIES	FREQUENCY (MHz)	SUPPLY VOLTAGE (Vcc)	STABILITY (ppm)	TEMPERATURE RANGE (°C)	SYMMETRY (Duty Cycle)	TAPE & REEL
Clock Oscillator RCP	3225	13.500 ~ 156.250 MHz	2.5: Vcc=2.5 3.3: Vcc=3.3	25: ±25 ppm 50: ±50 ppm 100: ±100 ppm	blank: -10°C to +70°C X: -40°C to +85°C	blank: 40 to 60% T: 45 to 55%	TR

EXAMPLE: RCP3225-60.000-2.5-25-X-T-TR

Surface Mount CP3225LVPECL Oscillator, 3.2 x 2.5 mm, 60.000 MHz, 2.5 VDC Supply Voltage, ±25 ppm Overall Stability, from -40°C to +85°C, Symmetry 45% to 55%, Tape and Reel packaging.

❖ REFLOW PROFILE

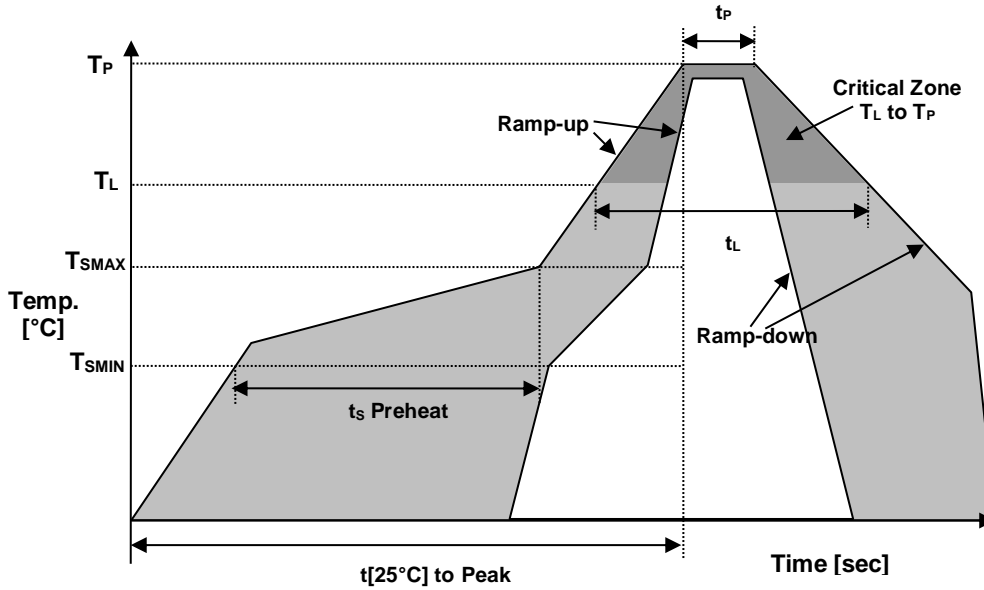

Reflow profile		
Temperature Min Preheat	T_{SMIN}	150°C
Temperature Max Preheat	T_{SMAX}	200°C
Time (T_{SMIN} to T_{SMAX})	t_s	60-180 sec.
Temperature	T_L	217°C
Peak Temperature	T_P	260°C
Ramp-up rate	R_{UP}	3°C/sec max.
Ramp-down rate	R_{DOWN}	6°C/sec max.
Time within 5°C of Peak Temperature	t_p	10 sec.
Time $t[25^\circ\text{C}]$ to Peak Temperature	$t[25^\circ\text{C}]$ to Peak	480 sec.
Time	t_L	60-150 sec.

❖ ENVIRONMENTAL

PARAMETER	VALUE
MOISTURE SENSITIVITY LEVEL	1
REACH SVHC	COMPLIANT
RoHS	COMPLIANT
TERMINATION FINISH	Au

